

Ra 5

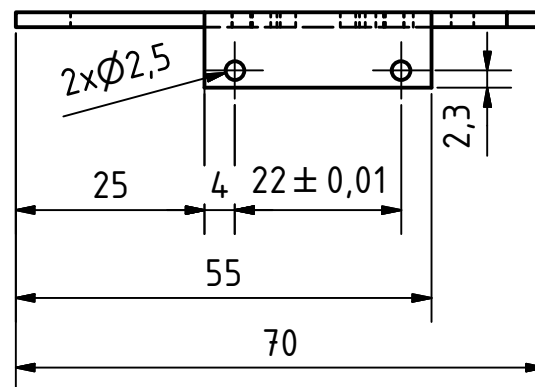

Comments:
1. Blunt sharp edges

Odchyłki wymiarów nietolerowanych powierzchni obrabianych.												
wymiar powyżej-do	0,5-3	3-6	6-30	30-120	120-315	315-1000	1000-2000	2000-3150	3150-5000	5000-8000	8000-10000	
wartość	$\pm 0,1$	$\pm 0,1$	$\pm 0,2$	$\pm 0,3$	$\pm 0,5$	$\pm 0,8$	$\pm 1,2$	± 2	± 3	± 5	± 8	
Odchyłki wymiarów ściąg i promieni zaokrąglen krawędzi.								Odchyłki katów.				
wymiar powyżej-do	0,3-1	1-3	3-6	6-30	30-120	120-315	315-1000	dł. krótszego ramienia kąta	do 40	40-160	160-630	630-2500
wartość	$\pm 0,1$	$\pm 0,2$	$\pm 0,3$	$\pm 0,5$	± 1	± 2	± 4	wartość	$\pm 30'$	$\pm 20'$	$\pm 10'$	$\pm 5'$

Zmiany dopuszczalne jedynie w systemach CAD. Changes allowed in CAD-System only.

CAD-MECH Sp. z o. o.

52-314 Wrocław ul. Wałbrzyska 26
tel./faks: +48 71 797 52 83
e-mail: cadmech@cadmech.pl
e-mail: office@cadmech.com.pl



Material PA6	Mass (Kg) 0,021 kg	Title Mounting	Unit 80001272
Heat treatment			Item 316
			Scale 1:1
Drawn B.Juraszek	Date 2014-01-31	Drw number 40009490	Nr.Rev
Checked			Format A3
Approved		Nazwa pliku 40009490.idw	Sheet 1
Zastrzegamy sobie prawa autorskie do tego rysunku. Kopiowanie, rozpowszechnianie i udostępnianie osobom trzecim tego rysunku bez naszego zezwolenia jest zabronione. Każde nadużycie będzie karane.			All rights to the drawing reserved. Distribution, posting or copying of the drawing is strictly prohibited without our written permission. Any possible misuse will be penalized according to the law.

